



***GAMA SONIC***<sup>®</sup>  
**SOLAR LIGHTING**

2024

## TABLE OF CONTENTS

Gama Sonic® - Who we are	3
Why Breakthrough Technology Matters	4
Commercial Series By Gama Sonic®	6
Centennial Commercial Solar LED Post Light	8
Modern Commercial Solar LED Post Light	10
Denali Commercial Solar LED Post Light	12
Imperial III Commercial Solar Post Light	14
Contemporary Square Solar Post Light	16
Imperial Bulb ATS Commercial Solar Post Light	17
Everest II Commercial Solar Lamp	18
Plaza Solar Light	19
Solar Flood Light	20
Solar Security & Area Light	21
Solar Pillar Commercial Bollard	22
Vantage Bollard Solar Pathway Light	23
Bulbs	24
Batteries	24
Accessories	24
Posts	25

## Who We Are

Gama Sonic® is the world leader in upscale, high quality solar lighting for homes, businesses and outdoor spaces. We develop, manufacture and market residential and commercial/industrial grade, energy-efficient outdoor solar powered lighting products. Since 2001, our multiple patented technologies have introduced innovative and cost-effective outdoor solar lighting solutions that provide unsurpassed levels of illumination and reliability. Gama Sonic® distributes products around the globe.

### OUR MISSION

Our singular mission is to provide a solar solution for replacing traditional gas and electrical fixtures with an equivalent look, quality, duration and brightness. Gama Sonic® Solar lights can be easily installed anywhere outdoors without any electrical wiring, trenching or digging, and most importantly, without compromising performances of traditional lighting.



Norcross, GA

## Our Story

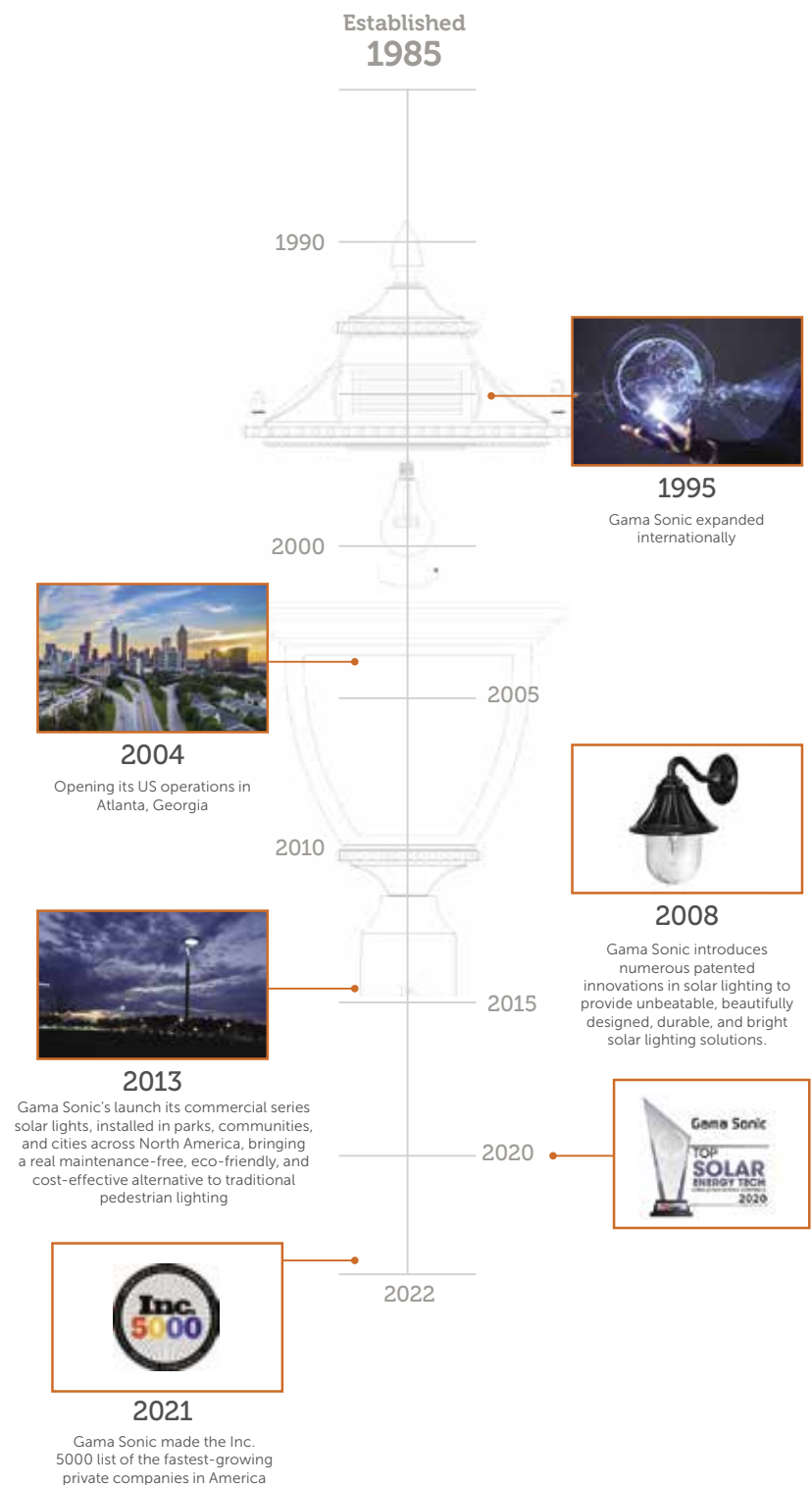













## Why Breakthrough Technology Matters

### Over Twenty (20) Design and Utility Patents

No matter what outdoor lighting challenges you face, choosing a technology-rich solution makes all the difference. Solar-powered products have been around for years, but it took the research and development expertise of Gama Sonic® engineers to create rechargeable solar lighting designs that outshine and outlast every major competitor. We stay ahead of the design curve by creating and testing products that fit a wide variety of residential and commercial applications.

What this means to you: Enjoying a safer, more reliable, and more cost-effective investment for your lighting budget.

 LED Technology	 Easy Installation	 No Wiring
 Weather Resistant	 Maintenance Free	 Cost Efficient
 Eco Friendly	 2 Year Warranty (Residential Products)	 5 Year Warranty (Commercial Products)



**GS Cone Technology** is a patented technology which allows our solar lamps to disburse more light efficiently and spreading the directional LED rays down and around the light fixture.

**Patent #7172307**



**Morph Solar Panel Technology** is our ground-breaking process of capturing more power from the sun. Monocrystalline solar cells are molded to the surface of the lamp, "morphing" the lamp into a solar panel.



**Translucent Solar Panel (TSP)** is an industry changing technology that transforms the largest surface areas of the light fixture into solar panels - the glass panes. This innovative technology embeds the monocrystalline solar cells into the glass, maximizing the power from the sun.



**Automatic Tracking System (ATS)** technology is revolutionizing the way to maximize the sun's rays in charging solar lights. This technology, previously used in large solar farms, is now available to the consumer to track the sun throughout the day and provides a longer lasting and brighter light.

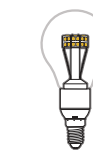

**GS Solar LED Light Bulb** is a patented technology that replicates the conventional look and feel of the traditional bulb in outdoor solar-powered lamps.

**Patent #9458970**



# Commercial Series by **GAMA SONIC®**

Since 2013, Gama Sonic's Commercial Series line has been installed in parks, communities and cities across North America, bringing a real maintenance-free, eco-friendly, and cost-effective alternative to traditional pedestrian lighting.

Our Partners:







## Centennial Commercial Solar LED Post Light

- Commercial grade construction
- Coastal approved
- IP65 - weather resistant rating
- 64 SMD LEDs
- Corrosion resistant powder-coated cast aluminum
- 22W tempered glass SunPower™ solar panel
- Exterior low/off/high switch
- Automatic dusk to dawn operation
- Patent #7172307

  
**1000**  
LUMENS

  
**4-8**  
NIGHTS  
DURATION

**3X**   
LIFEPO4 batteries  
**GS12\_8V60**  
GAMA SONIC  
BATTERY

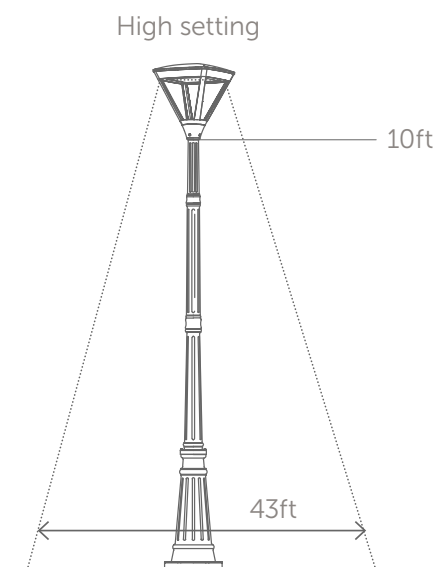
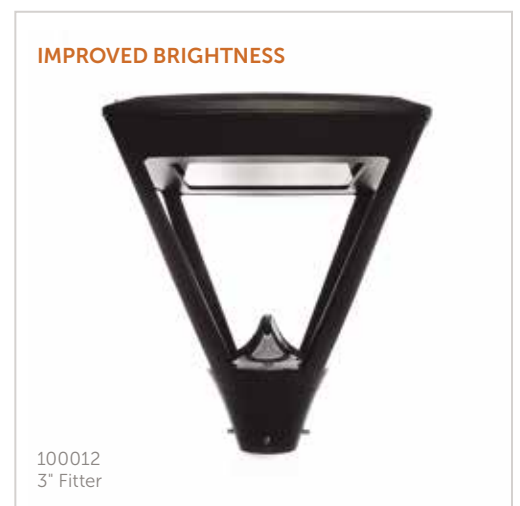

\*Beam diameter is based on quantity of illumination [IES Recommended Light Levels] RP-8-18 for Walkways/Bikeways of a minimum 0.2 Foot Candle.

The Centennial Solar Light is a commercial grade, high-performance solar lamp providing a stunning 1000 lumens of bright white (6000K) light for up to 8 nights. This solar lamp's weather resistant, coastal approved construction is perfect for commercial and residential areas such as pedestrian walkways, parking lots, and community parks. The Centennial Solar Light is the practical solution for any outdoor lighting application.

Part #	Dimensions	UPC	Wgt	LED Color	Lamp Color
100012	18.5L x 18.5W x 20H	859641007240	30	Bright White (6000K)	Black
100012-5	18.5L x 18.5W x 20H	859641007240	30	Warm White (2700K)	Black





## Modern Commercial Solar LED Post Light w/ Motion Sensor and Timer

- Commercial grade construction
- Coastal approved
- IP65 - weather resistant rating
- 24 SMD LEDs
- Corrosion resistant powder coated cast aluminum
- Powered by efficient monocrystalline solar panel
- Exterior low/off/high switch
- Automatic dusk to dawn operation
- 140° Detection zone
- 2 modes of operation: PIR / Constant On
- 20W tempered glass solar panel
- Timer feature allows 4-8 hours of duration or dusk to dawn operation



4,5,6,7,8 hours duration  
or 0 for dusk to dawn  
operation

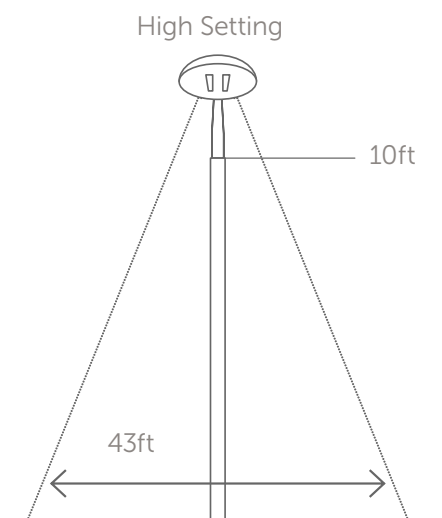

\*Beam diameter is based on quantity of illumination [IES Recommended Light Levels] RP-8-18 for Walkways/Bikeways of a minimum 0.2 Foot Candle.

The unique, contemporary style of the Modern Commercial Grade Solar Post Light makes it perfect for any outdoor space, especially parks, commercial grounds, and residential communities. It fits standard 3" posts and is an excellent choice for replacing and retrofitting outdated gas or traditional electric lights. The light turns on automatically from dusk until dawn and, for added versatility, allows you to choose between a high or low output at the flip of a switch.

Part #	Dimensions	UPC	Wgt	LED Color	Lamp Color
102iST60012	19.5L x 19.5W x 28H	859641008261	24.6	Bright White (6000K)	Black





## Denali Commercial Solar LED Post Light w/ Timer

- Commercial grade construction
- 33 SMD LEDs
- IP65 - weather resistant rating
- Powered by efficient monocrystalline solar panels
- Morph Technology
- Automatic dusk to dawn operation
- UV inhibited polycarbonate weather resistant lamp head
- Powder coated cast-aluminum weather resistant structure
- 26W solar panel
- Timer feature allows 4-8 hours of duration or dusk to dawn operation

  
600  
LUMENS

  
3-6  
NIGHTS  
DURATION

2X   
GS32V12A  
GAMA SONIC  
BATTERY



4,5,6,7,8 hours duration  
or 0 for dusk to dawn  
operation

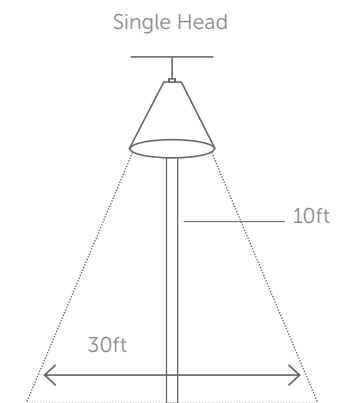
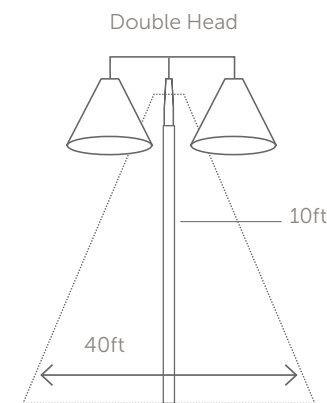

\*Beam diameter is based on quantity of illumination [IES Recommended Light Levels] RP-8-18 for Walkways/ Bikeways of a minimum 0.2 Foot Candle.

Gama Sonic's Denali is a commercial grade pedestrian lighting featuring Gama Sonic's exclusive Morph Technology where the solar panels are morphed into the light fixture for more powerful solar charge and longer light output. Mount the Denali as a single head or double head, this beautifully designed solar post light can be used to illuminate parks, communities, sidewalks, and campgrounds.

Part #	Dimensions	UPC	Wgt	LED Color	Lamp Color
229iM60012	23.125 L x 16.5W x 19.875H	859641008292	13	Bright White (6000K)	Black



## Imperial III Commercial Solar Post Light

- Commercial grade construction
- 21 SMD LEDs
- Dual color - bright white/warm white
- Automatic dusk to dawn operation
- Powered by efficient monocrystalline solar panels
- Powder coated cast-aluminum weather resistant structure
- Beveled glass panes
- Patent #7172307
- 8W tempered glass solar panel

  
300  
LUMENS

  
3-6  
NIGHTS  
DURATION

4X   
GS32V30  
GAMA SONIC  
BATTERY

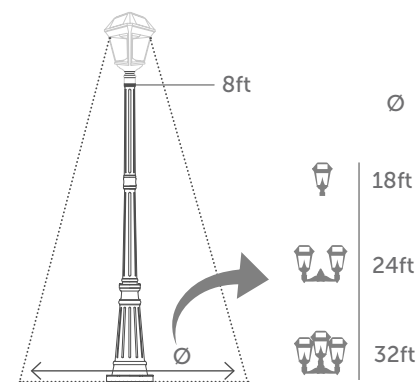

\*Beam diameter is based on quantity of illumination [IES Recommended Light Levels] RP-8-18 for Walkways/Bikeways of a minimum 0.2 Foot Candle.

The Imperial III Solar Light is a commercial grade solar lamp featuring both a warm-white (2700K) and bright white (6000K) light temperature, provided at a brilliant 300/600/900 lumens and for up to 6 nights (300 lumen per lamp). Continuing the Imperial series reputation for durability, functionality and style, its weather resistant construction is perfect for commercial and residential areas such as pedestrian walkways, parking lots, and community parks.

Part #	Dimensions	UPC	Wgt	LED Color	Lamp Color
97K012	10.5L x 10.5W x 19.5H	859641007462	9.4	Bright White (6000K) + Warm White (2700K)	Black
97KF20	30L x 10.5W x 21.5H	859641007639	21.2		
97KF30	26.5L x 24.5W x 21.5H	859641007646	31.2		



## Contemporary Square Solar Post Light w/ Timer



- Powered by efficient monocrystalline solar panels
- Automatic dusk to dawn operation
- Corrosion resistant powder coated cast aluminum
- 3 color temperature options: Warm White (3000K) / Natural White (4000K) / Bright White (5000K)
- 14W tempered glass solar panel
- 2 mounting options: center mount and side mount
- Timer feature allows 4-8 hours of duration or dusk to dawn operation

**500** LUMENS  
**2-4** NIGHTS DURATION  
**GS32V15A** GAMA SONIC BATTERY

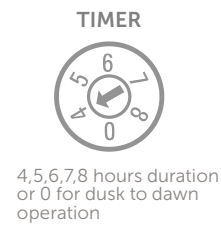
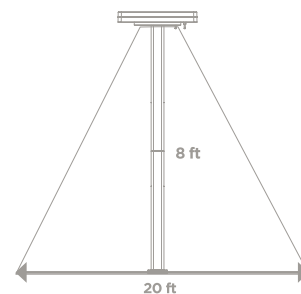

Part #	Dimensions	UPC	Wgt	LED Color	Lamp Color
217i20001	17.5L x 12.25W x 98.75H	859641008780	19	3000K/4000K/5000K	Black
217i20012	12.25L x 12.25W x 5H	859641008797	7.4		

## Imperial Bulb ATS Commercial Solar Post Light



- Automatic Tracking System
- Commercial grade construction
- Automatic dusk to dawn operation
- Powered by efficient monocrystalline solar panel
- Powder coated cast-aluminum weather resistant structure
- Beveled glass panes
- Patents #7172307, #9458970
- 10W tempered glass solar panel

**550** LUMENS  
**3-6** NIGHTS DURATION  
**2X GS37V10\_4A** GAMA SONIC BATTERY

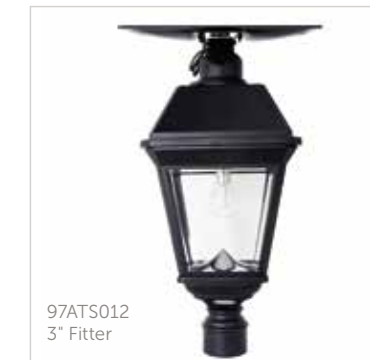

Automatic Tracking System follows the sun throughout the day

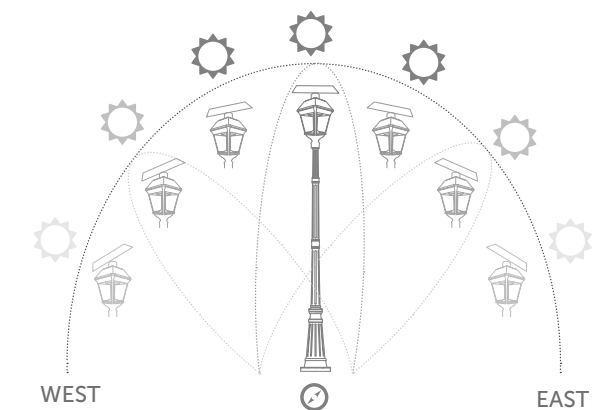

\*Beam diameter is based on quantity of illumination (IES Recommended Light Levels) RP-8-18 for Walkways/Bikeways of a minimum 0.2 Foot Candle.

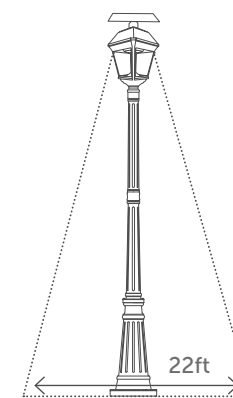

Part #	Dimensions	UPC	Wgt	LED Color	Lamp Color
97ATS012	13.5L x 9.5W x 24H	859641007349	13.7	Warm White (2700K)	Black

## Everest II Commercial Solar Lamp



- Commercial grade construction
- Automatic dusk to dawn operation
- Powered by efficient monocrystalline solar panel
- Cast-aluminum all weather-resistant structure with UV protection
- Exterior low/off/high switch
- Acrylic lens
- Patent #9458970
- 10W tempered glass solar panel

500  
LUMENS

5-10  
NIGHTS  
DURATION

GS37V27A  
GAMA SONIC  
BATTERY

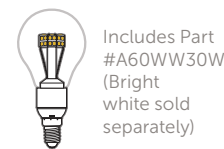
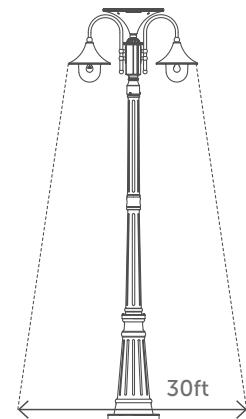
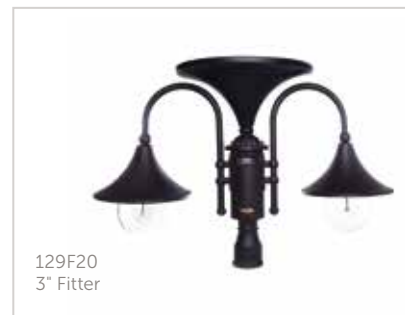

\*Beam diameter is based on quantity of illumination [IES Recommended Light Levels] RP-8-18 for Walkways/Bikeways of a minimum 0.2 Foot Candle.

Part #	Dimensions	UPC	Wgt	LED Color	Lamp Color
129F20	15.75L x 34W x 23H	859641007233	23	Warm White (2700K)	Black

## Plaza Solar Light



- Morph technology
- Powered by efficient monocrystalline solar panels
- Automatic dusk to dawn operation
- UV inhibited polycarbonate lamp head
- Powder coated cast-aluminum structure
- Rigid ABS resin weather resistant structure
- Cast-aluminum mounting arm/bracket
- Exterior low/off/high switch
- Patent #9458970
- 8W solar panel

180  
LUMENS

2  
NIGHTS  
DURATION

2X  
GS32V30  
GAMA SONIC  
BATTERY

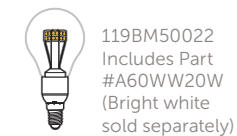

119B50044  
Includes Part #A60WW20W-DIR



Part #	Dimensions	UPC	Wgt	LED Color	Lamp Color
119B50044	11L x 42W x 21H	859641007356	10.12	Warm White (2700K)	Black
119BM50022	10.63L x 10.63W x 18.25H	859641007950	3.6		



## Solar Flood Light

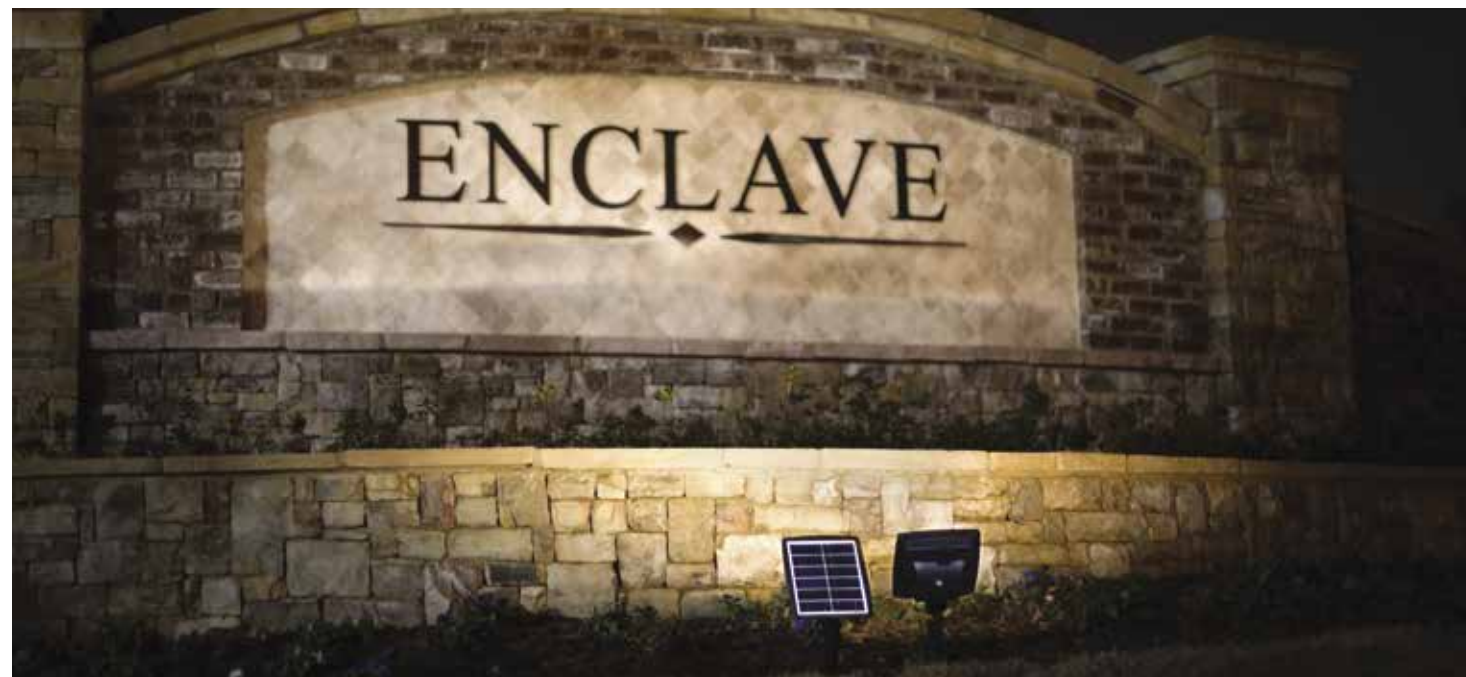

- IP65 - weather resistant rating
- Automatic dusk to dawn operation
- 20 bright SMD LEDs
- Cast-aluminum weather resistant structure
- 2 mounting options
- Exterior low/off/high switch
- 4W tempered glass solar panel
- Detachable panel with 6ft cord

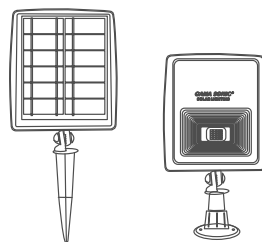
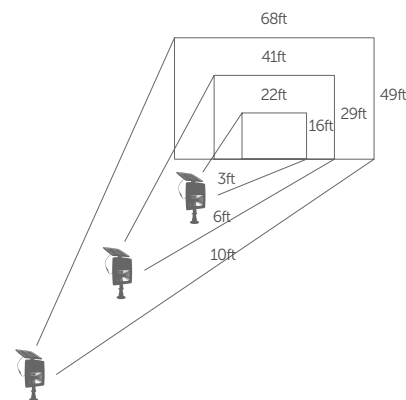

**250** LUMENS  
**Up to 20** HOURS DURATION  
**2X GS37V40** GAMA SONIC BATTERY

Part #	Quantity	Dimensions	UPC	Wgt	LED Color	Lamp Color
203001	1 Pack	2.5L x 8W x 18H	859641007165	6	Bright White (6000K)	Black
203iP260090	2 Pack		859641008094			
203001-5	1 Pack		859641007172			
203iP250090	2 Pack		859641008179			

## Solar Security & Area Light with Motion Sensor and Timer



- 810 Lumens (as Security Light)
- 100 Cycles (as Security Light)
- 270 Lumens (as Area Light)
- Up to 1 nights duration (as Area Light)
- GS37V60 Battery
- 4W tempered glass solar panel

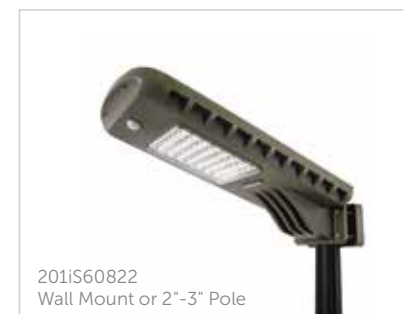

- 1620 Lumens (as Security Light)
- 150 Cycles (as Security Light)
- 500 Lumens (as Area Light)
- Up to 2 nights duration (as Area Light)
- GS37V16A Battery
- 10W tempered glass solar panel



- 2800 Lumens (as Security Light)
- 150 Cycles (as Security Light)
- 980 Lumens (as Area Light)
- Up to 2 nights duration (as Area Light)
- GS32V24A Battery
- 16W tempered glass solar panel

- IP65 - weather resistant rating
- 2 mounting options
- ABS plastic housing optimal for outdoor usage
- PIR/off/on switch
- 2 modes of operation: PIR or constant on
- Timer feature allows 4-8 hours of duration or dusk to dawn operation



PIR/OFF/ON SWITCH



PIR Mode: Light turns on when motion is detected  
On Mode: Constant on

TIMER



4,5,6,7,8 hours duration or 0 for dusk to dawn operation

Part #	Dimensions	UPC	Wgt	LED Color	Lamp Color
101iS60822	12L x 6W x 2H	859641008223	2	Bright White (6000K)	Dark Grey
201iS60822	20L x 8.5W x 2H	859641007837	5.5		
301iS60822	22.50L x 10.25W x 4H	859641008346	11.10		

## Solar Pillar Commercial Bollard



- Bifacial solar panel technology
- 2 modes of operation: PIR 150 cycles/constant on mode with dusk to dawn operation
- Cast-aluminum weather resistant structure
- Bi-directional or mono-directional Light output
- 19W tempered glass solar panel

Integrated PIR motion sensor



500 LUMENS

up to 2 NIGHT DURATION

GS64V60 GAMA SONIC BATTERY

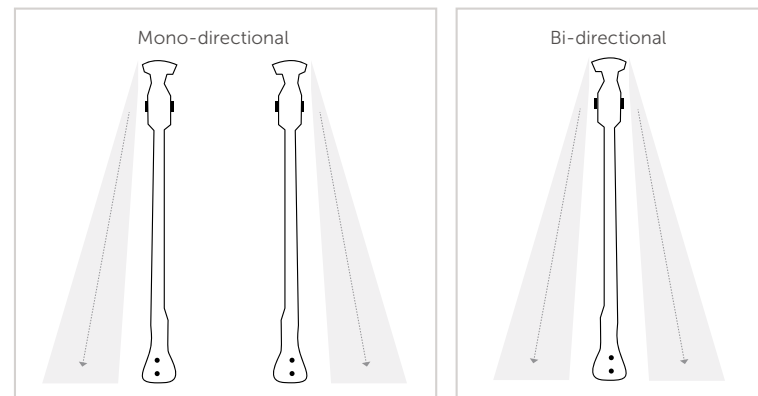

Part #	Dimensions	UPC	Wgt	LED Color	Lamp Color
9iD50800	8.75L x 3.5W x 31.25H	859641007851	11	Warm White (3000K)	Black

## Vantage Bollard Solar Pathway Light



- Powered by efficient monocrystalline solar panels
- Automatic dusk to dawn operations
- Cast-aluminum weather resistant structure
- Patents #9458970, #7172307
- 4.5W tempered glass solar panel
- 2 installation mounting option included: flat mount and stake mount

200 LUMENS

up to 3 NIGHTS DURATION

3X GS32V30 GAMA SONIC BATTERY



314B50000 Flat Mount and Stake Mount

Includes Part #A60BW20W (Bright white sold separately)

Part #	Quantity	Dimensions	UPC	Wgt	LED Color	Lamp Color
314B50000	1 Pack	10.25L x 10.25W x 31.25H	859641008407	4.4	Warm White (2700K)	Black
314BP250000	2 Pack		854433001086			



# Accessories

## Batteries

Gama Sonic® uses the highest quality batteries and technology to power our solar lights. Our batteries are strategically matched with a solar lamp to maximize its duration and brightness. As technology continues to be increasingly important in the growing solar lighting world, we set the industry standard on quality battery solutions. We only use specially designed products that are packed, sealed, and use an external harness to eliminate corrosion and provide the superior charging and powering of the light our customers expect.

To learn more visit [gamasonic.com](http://gamasonic.com)

### New turtle safe bulbs available\*

- A50TL10W
- A60TL20W
- C37TL10W

## GS Solar LED Light Bulb

Patent #945897

Works only with Gama Sonic bulb series fixtures

 <p>A50WW10W A50BW10W A50TL10W* 11 LEDs 220mA/0.7W</p>	 <p>A60WW30W A60BW30W 27 LEDs 1A/3.5W</p>	 <p>A60WW20W A60BW20W A60TL20W* 11 LEDs 440mA/1.5W</p>
 <p>C37WW10W C37BW10W C37TL10W* 11 LEDs 600mA/2W</p>	 <p>A60WW20W-DIR A60BW20W-DIR 4+7 LEDs 440mA/1.5W</p>	 <p>T45WW10W Filament Style 220mA/0.75W</p>
 <p>F30WW05W Simulated Flame Style 40 LEDs 220mA/0.75W</p>	 <p>D46WW05W 6 LEDs 220mA/0.75W</p>	

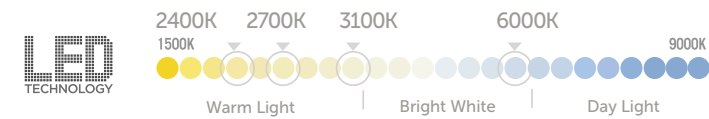

## EZ-Anchor Solar Lamp Post Anchor Kit



\*Not applicable on commercial posts

**STEP 1**

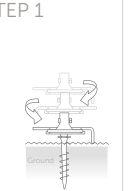

Install the EZ Anchor

**STEP 2**

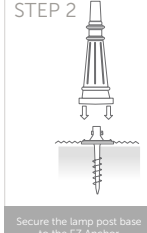

Secure the lamp post base to the EZ Anchor

**STEP 3**

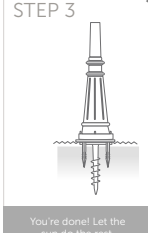

You're done! Let the sun do the rest.

NOTE: 30001 EZ-Anchor Lamp Post Base is built to support ONLY single lamps on a Gama Sonic® Decorative or Imperial Post. DO NOT USE to support multi-lamp products.

### Pier Base Mount for 3" Post Top Mounts

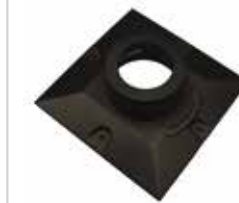

PBM00

### Universal Wall Bracket



97NWKIT0

Part #	UPC	Pkg. Size (in)	Wgt
30001	185455000024	26L x 12W x 12H	6
97NWKIT0	NA	9L x 8W x 6H	1.5
PBM00	859641007387	6.25L x 6.25W x 2.25H	0.4



## Posts

- All our poles fit most 3" post top fixtures
- Matte finish cast aluminum weather resistant poles

### Commercial Posts

 <p>CP65F0 6.5 FT.</p>	 <p>CP8F0 8 FT.</p>	 <p>CP10F0 10 FT.</p>	 <p>**DBP10F0 10 FT.</p>
---	--	--	---

\*\* Requires freight shipping

### Residential Posts

 <p>DPEZ5F0 Black 64"</p>	 <p>97SP0 Black 78"</p>	 <p>DP55F2 White 68"-79" DP55F0 Black 68"-79"</p>	 <p><b>NEW</b> * MP8F0 Black 96"</p>
---	---	---	--

\* Only applicable to 21720012 and 66B50010

Part #	UPC	Pkg. Size (in)	Wgt
CP65F0	853153005855	11.6L x 15.5W x 29H	20
CP8F0	853153005756	11.6L x 15.5W x 38H	22
CP10F0	853153005763	11.6L x 15.5W x 48.5H	25
DP55F2	185455000239	9L x 11W x 24H	8
DP55F0	185455000185		
97SP0	185455000031	12.5L x 10W x 32H	11
DPEZ5F0	859641008148	9.75L x 25.13W x 13H	8
DBP10F0	859641008353	3L x 3W x 143.25H	19.6
MP8F0	859641008803	COMING SOON	COMING SOON
BP28INEZ0	859641007844	5L x 5W x 28.25H	2.40

# ***GAMA SONIC***<sup>®</sup> **SOLAR LIGHTING**



Gama Sonic USA Inc.

6185-F Jimmy Carter Boulevard  
Norcross, Georgia 30071 USA

Matt Cohen  
matt@gamasonic.com  
727-688-5030